

TECHNICAL DATA SHEET



ALTERNATOR E1W13M/4 250DC
DC brushless welder

E1W13M/4 250DC

COMMON DATA

Rated Power at 50Hz	kVA	11	
Rated Power at 60Hz	kVA	13,2	
Rated Power Factor		0,8	
Nominal Temperature	°C	40	
Control System		self-excited	
Execution		brushless	
Insulation Class		H	
Protection		IP21	
Maximum Over speed	rpm	2250	
Overload		110% of rated power for one hour in a cycle of 6 hours	
Air Flow Requirement	m ³ /min	4,3 at 50Hz	5,2 at 60Hz
R.F.I. Suppression		Standard EN55011	

REGULATION DATA

Regulation		SG132
Sensing		Single-Phase
Voltage Regulation		±1%

WINDING DATA

Rotor Winding		with damping cage
Number of Leads of Stator		6
Stator Winding Resistance	Ω	1,01 at 20°C
Rotor Winding Resistance	Ω	9,46 at 20°C
Exciter Stator Resistance	Ω	16,5 at 20°C
Exciter Rotor Resistance	Ω	2,15 at 20°C

STANDARD

References		EN60034-1 ISO8528-3 EN55011
------------	--	-----------------------------

E1W13M/4 250DC

ELECTRICAL DATA

No load voltage	V _{AC}	80
Welding voltage	V _{AC}	20-30
Regulation range	A _{AC}	35-250
Max. current at 35%	A _{AC}	250
Max. current at 60%	A _{AC}	195
Max. current at 100%	A _{AC}	150
Stator Winding Resistance	Ω	0,034 at 20°C
Electrodes type		basic; cellulosic; inox, rutile
Electrodes diameter	mm	1 - 5

MECHANICAL DATA

Bearing non drive end		6305-2Z-C3	
Bearing drive end (B3/B14 form)		6208-2Z-C3	
Weight of generator	in B2	kg	108
	in B3/B14	kg	103,9
	in B3/B9	kg	\

MOMENT OF INERZIA

B3/B9	kg·m ²	\
SAE 7½	kg·m ²	0,091
SAE 8	kg·m ²	0,091
SAE 10	kg·m ²	0,091
SAE 11½	kg·m ²	0,091
SAE 14	kg·m ²	\
SAE 18	kg·m ²	\
B3/B14	kg·m ²	0,088

E1W13M/4 250DC

DERATING CURVES

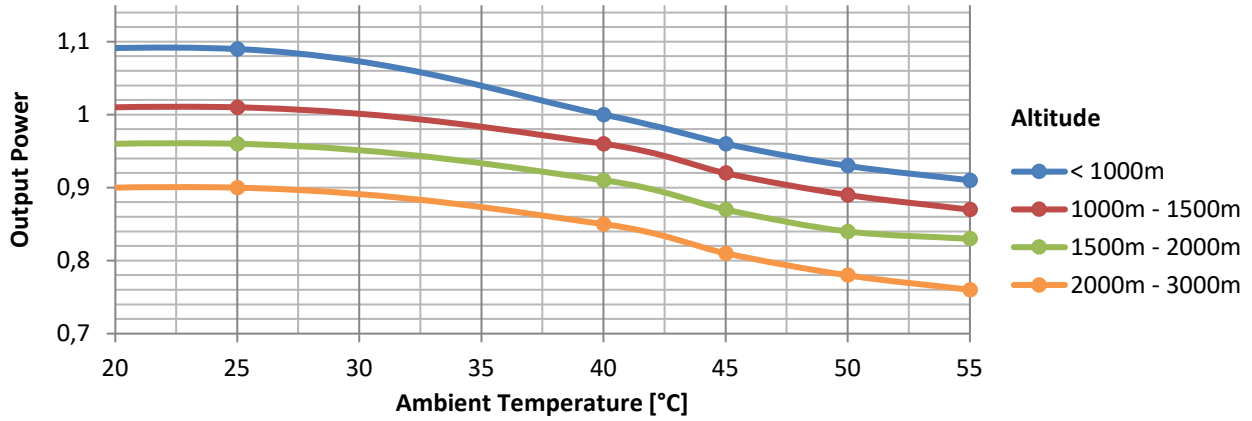

WIRING DIAGRAM

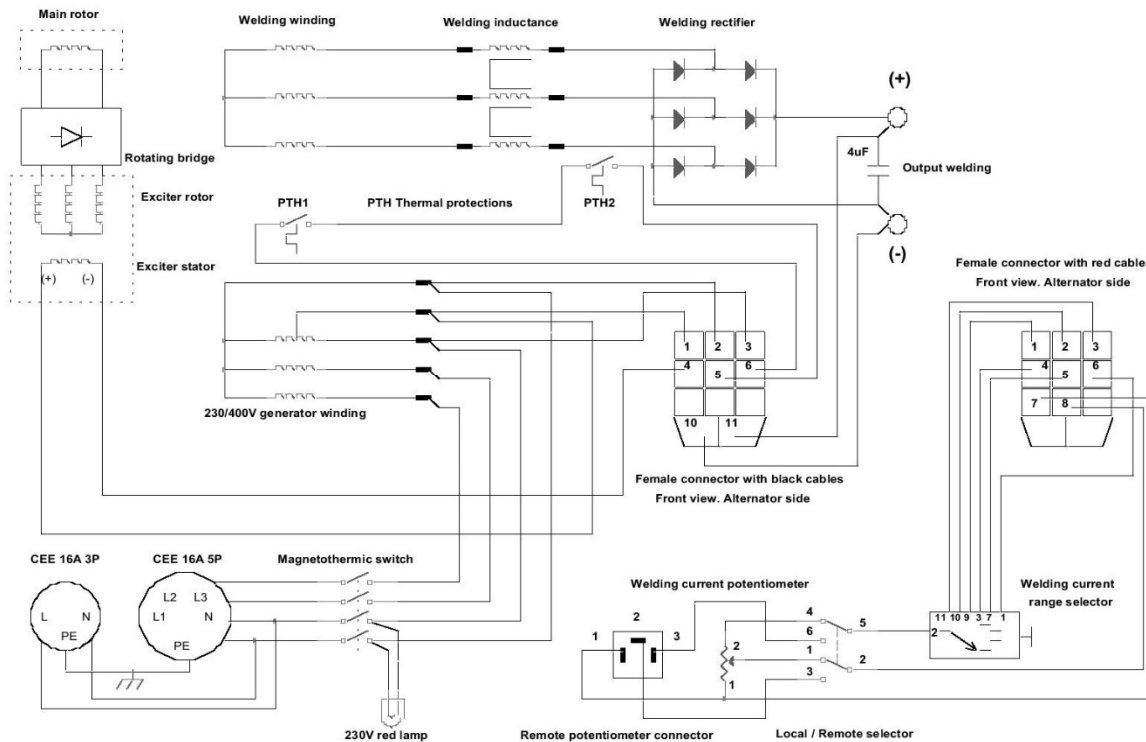

E1W13M/4 250DC

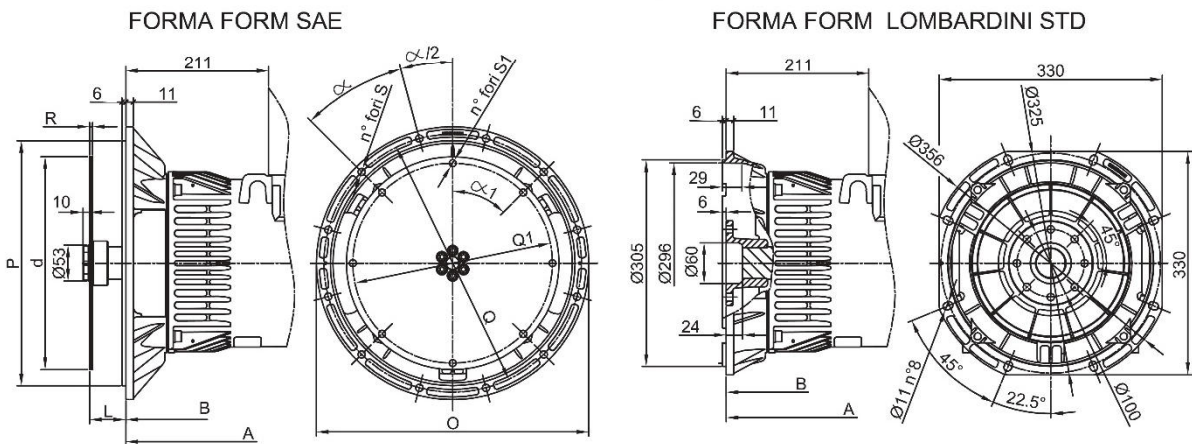
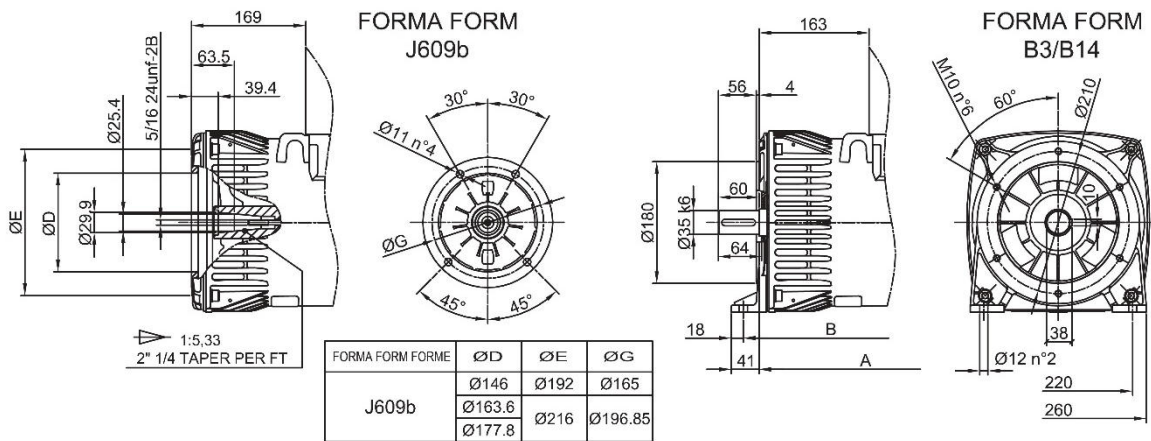
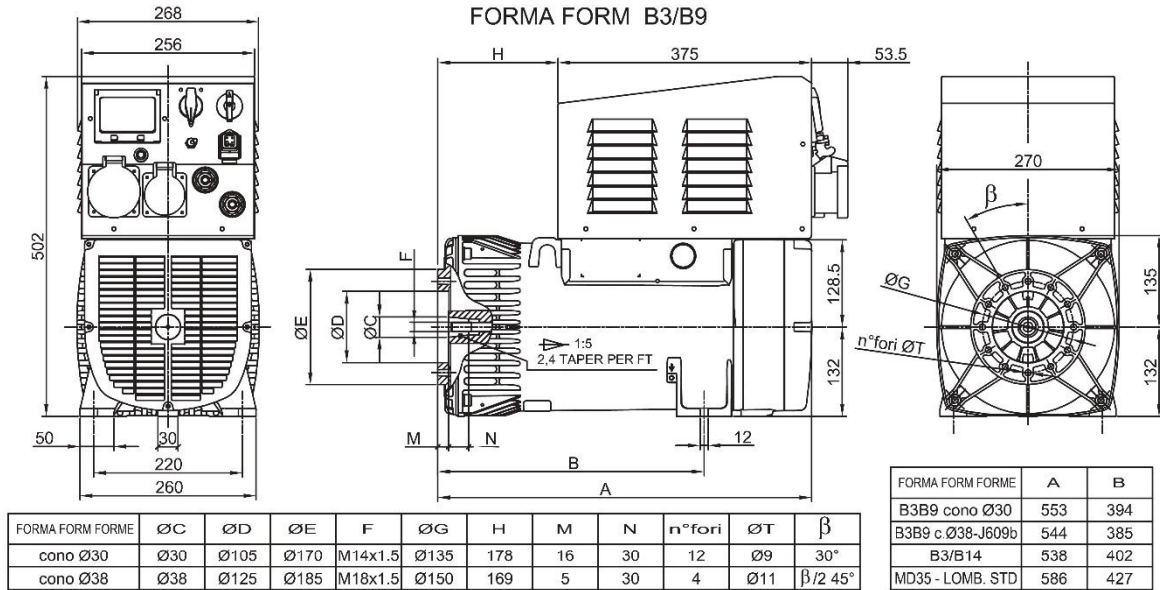

SAE N.	FLANGE - FLANGES						GIUNTI A DISCO - COUPLING DISCS							
	O	P	Q	n. fori	S	α	N.	L	d	Q1	n. fori	S1	α1	R
5	356	314.3	333.4	8	11	45°	6 1/2	30.2	215.9	200	6	9	60°	3
4	403	362	381	12	11	30	7 1/2	30.2	241.3	222.25	8	9	45°	
3	451	409.6	428.6	12	11	30	8	62	263.52	244.47	6	10.5	60	
							10	53.8	314.32	295.27	8	10.5	45°	4.5
							11 1/2	39.6	352.42	333.37	8	10.5	45°	